

# ENGENHARIA ELÉTRICA:

Desenvolvimento e Inovação Tecnológica

João Dallamuta  
Henrique Ajuz Holzmann  
(Organizadores)

 **Atena**  
Editora  
Ano 2021

# ENGENHARIA ELÉTRICA:

## Desenvolvimento e Inovação Tecnológica

João Dallamuta  
Henrique Ajuz Holzmann  
(Organizadores)

 **Atena**  
Editora  
Ano 2021

**Editora Chefe**

Profª Drª Antonella Carvalho de Oliveira

**Assistentes Editoriais**

Natalia Oliveira

Bruno Oliveira

Flávia Roberta Barão

**Bibliotecária**

Janaina Ramos

**Projeto Gráfico e Diagramação**

Natália Sandrini de Azevedo

Camila Alves de Cremona

Luiza Alves Batista

Maria Alice Pinheiro

**Imagens da Capa**

Shutterstock

**Edição de Arte**

Luiza Alves Batista

**Revisão**

Os Autores

2021 by Atena Editora

Copyright © Atena Editora

Copyright do Texto © 2021 Os autores

Copyright da Edição © 2021 Atena Editora

Direitos para esta edição cedidos à Atena Editora pelos autores.



Todo o conteúdo deste livro está licenciado sob uma Licença de Atribuição *Creative Commons*. Atribuição-Não-Comercial-NãoDerivativos 4.0 Internacional (CC BY-NC-ND 4.0).

O conteúdo dos artigos e seus dados em sua forma, correção e confiabilidade são de responsabilidade exclusiva dos autores, inclusive não representam necessariamente a posição oficial da Atena Editora. Permitido o *download* da obra e o compartilhamento desde que sejam atribuídos créditos aos autores, mas sem a possibilidade de alterá-la de nenhuma forma ou utilizá-la para fins comerciais.

Todos os manuscritos foram previamente submetidos à avaliação cega pelos pares, membros do Conselho Editorial desta Editora, tendo sido aprovados para a publicação com base em critérios de neutralidade e imparcialidade acadêmica.

A Atena Editora é comprometida em garantir a integridade editorial em todas as etapas do processo de publicação, evitando plágio, dados ou resultados fraudulentos e impedindo que interesses financeiros comprometam os padrões éticos da publicação. Situações suspeitas de má conduta científica serão investigadas sob o mais alto padrão de rigor acadêmico e ético.

**Conselho Editorial**

**Ciências Humanas e Sociais Aplicadas**

Prof. Dr. Alexandre Jose Schumacher – Instituto Federal de Educação, Ciência e Tecnologia do Paraná

Prof. Dr. Américo Junior Nunes da Silva – Universidade do Estado da Bahia

Prof. Dr. Antonio Carlos Frasson – Universidade Tecnológica Federal do Paraná



Prof. Dr. Antonio Gasparetto Júnior – Instituto Federal do Sudeste de Minas Gerais  
Prof. Dr. Antonio Isidro-Filho – Universidade de Brasília  
Prof. Dr. Carlos Antonio de Souza Moraes – Universidade Federal Fluminense  
Prof. Dr. Crisóstomo Lima do Nascimento – Universidade Federal Fluminense  
Prof<sup>ª</sup> Dr<sup>ª</sup> Cristina Gaio – Universidade de Lisboa  
Prof. Dr. Daniel Richard Sant’Ana – Universidade de Brasília  
Prof. Dr. Deyvison de Lima Oliveira – Universidade Federal de Rondônia  
Prof<sup>ª</sup> Dr<sup>ª</sup> Dilma Antunes Silva – Universidade Federal de São Paulo  
Prof. Dr. Edvaldo Antunes de Farias – Universidade Estácio de Sá  
Prof. Dr. Elson Ferreira Costa – Universidade do Estado do Pará  
Prof. Dr. Eloi Martins Senhora – Universidade Federal de Roraima  
Prof. Dr. Gustavo Henrique Cepolini Ferreira – Universidade Estadual de Montes Claros  
Prof<sup>ª</sup> Dr<sup>ª</sup> Ivone Goulart Lopes – Instituto Internazionele delle Figlie de Maria Ausiliatrice  
Prof. Dr. Jadson Correia de Oliveira – Universidade Católica do Salvador  
Prof. Dr. Julio Candido de Meirelles Junior – Universidade Federal Fluminense  
Prof<sup>ª</sup> Dr<sup>ª</sup> Lina Maria Gonçalves – Universidade Federal do Tocantins  
Prof. Dr. Luis Ricardo Fernandes da Costa – Universidade Estadual de Montes Claros  
Prof<sup>ª</sup> Dr<sup>ª</sup> Natiéli Piovesan – Instituto Federal do Rio Grande do Norte  
Prof. Dr. Marcelo Pereira da Silva – Pontifícia Universidade Católica de Campinas  
Prof<sup>ª</sup> Dr<sup>ª</sup> Maria Luzia da Silva Santana – Universidade Federal de Mato Grosso do Sul  
Prof<sup>ª</sup> Dr<sup>ª</sup> Paola Andressa Scortegagna – Universidade Estadual de Ponta Grossa  
Prof<sup>ª</sup> Dr<sup>ª</sup> Rita de Cássia da Silva Oliveira – Universidade Estadual de Ponta Grossa  
Prof. Dr. Rui Maia Diamantino – Universidade Salvador  
Prof. Dr. Urandi João Rodrigues Junior – Universidade Federal do Oeste do Pará  
Prof<sup>ª</sup> Dr<sup>ª</sup> Vanessa Bordin Viera – Universidade Federal de Campina Grande  
Prof. Dr. William Cleber Domingues Silva – Universidade Federal Rural do Rio de Janeiro  
Prof. Dr. Willian Douglas Guilherme – Universidade Federal do Tocantins

#### **Ciências Agrárias e Multidisciplinar**

Prof. Dr. Alexandre Igor Azevedo Pereira – Instituto Federal Goiano  
Prof<sup>ª</sup> Dr<sup>ª</sup> Carla Cristina Bauermann Brasil – Universidade Federal de Santa Maria  
Prof. Dr. Antonio Pasqualetto – Pontifícia Universidade Católica de Goiás  
Prof. Dr. Cleberton Correia Santos – Universidade Federal da Grande Dourados  
Prof<sup>ª</sup> Dr<sup>ª</sup> Daiane Garabeli Trojan – Universidade Norte do Paraná  
Prof<sup>ª</sup> Dr<sup>ª</sup> Diocléa Almeida Seabra Silva – Universidade Federal Rural da Amazônia  
Prof. Dr. Écio Souza Diniz – Universidade Federal de Viçosa  
Prof. Dr. Fábio Steiner – Universidade Estadual de Mato Grosso do Sul  
Prof. Dr. Fágner Cavalcante Patrocínio dos Santos – Universidade Federal do Ceará  
Prof<sup>ª</sup> Dr<sup>ª</sup> Girlene Santos de Souza – Universidade Federal do Recôncavo da Bahia  
Prof. Dr. Jael Soares Batista – Universidade Federal Rural do Semi-Árido  
Prof. Dr. Júlio César Ribeiro – Universidade Federal Rural do Rio de Janeiro  
Prof<sup>ª</sup> Dr<sup>ª</sup> Lina Raquel Santos Araújo – Universidade Estadual do Ceará  
Prof. Dr. Pedro Manuel Villa – Universidade Federal de Viçosa  
Prof<sup>ª</sup> Dr<sup>ª</sup> Raissa Rachel Salustriano da Silva Matos – Universidade Federal do Maranhão  
Prof. Dr. Ronilson Freitas de Souza – Universidade do Estado do Pará  
Prof<sup>ª</sup> Dr<sup>ª</sup> Talita de Santos Matos – Universidade Federal Rural do Rio de Janeiro  
Prof. Dr. Tiago da Silva Teófilo – Universidade Federal Rural do Semi-Árido

Prof. Dr. Valdemar Antonio Paffaro Junior – Universidade Federal de Alfenas

### **Ciências Biológicas e da Saúde**

Prof. Dr. André Ribeiro da Silva – Universidade de Brasília

Prof<sup>ª</sup> Dr<sup>ª</sup> Anelise Levay Murari – Universidade Federal de Pelotas

Prof. Dr. Benedito Rodrigues da Silva Neto – Universidade Federal de Goiás

Prof<sup>ª</sup> Dr<sup>ª</sup> Débora Luana Ribeiro Pessoa – Universidade Federal do Maranhão

Prof. Dr. Douglas Siqueira de Almeida Chaves – Universidade Federal Rural do Rio de Janeiro

Prof. Dr. Edson da Silva – Universidade Federal dos Vales do Jequitinhonha e Mucuri

Prof<sup>ª</sup> Dr<sup>ª</sup> Elizabeth Cordeiro Fernandes – Faculdade Integrada Medicina

Prof<sup>ª</sup> Dr<sup>ª</sup> Eleuza Rodrigues Machado – Faculdade Anhanguera de Brasília

Prof<sup>ª</sup> Dr<sup>ª</sup> Elane Schwinden Prudêncio – Universidade Federal de Santa Catarina

Prof<sup>ª</sup> Dr<sup>ª</sup> Eysler Gonçalves Maia Brasil – Universidade da Integração Internacional da Lusofonia Afro-Brasileira

Prof. Dr. Ferlando Lima Santos – Universidade Federal do Recôncavo da Bahia

Prof. Dr. Fernando Mendes – Instituto Politécnico de Coimbra – Escola Superior de Saúde de Coimbra

Prof<sup>ª</sup> Dr<sup>ª</sup> Gabriela Vieira do Amaral – Universidade de Vassouras

Prof. Dr. Gianfábio Pimentel Franco – Universidade Federal de Santa Maria

Prof. Dr. Helio Franklin Rodrigues de Almeida – Universidade Federal de Rondônia

Prof<sup>ª</sup> Dr<sup>ª</sup> Iara Lúcia Tescarollo – Universidade São Francisco

Prof. Dr. Igor Luiz Vieira de Lima Santos – Universidade Federal de Campina Grande

Prof. Dr. Jefferson Thiago Souza – Universidade Estadual do Ceará

Prof. Dr. Jesus Rodrigues Lemos – Universidade Federal do Piauí

Prof. Dr. Jônatas de França Barros – Universidade Federal do Rio Grande do Norte

Prof. Dr. José Max Barbosa de Oliveira Junior – Universidade Federal do Oeste do Pará

Prof. Dr. Luís Paulo Souza e Souza – Universidade Federal do Amazonas

Prof<sup>ª</sup> Dr<sup>ª</sup> Magnólia de Araújo Campos – Universidade Federal de Campina Grande

Prof. Dr. Marcus Fernando da Silva Praxedes – Universidade Federal do Recôncavo da Bahia

Prof<sup>ª</sup> Dr<sup>ª</sup> Maria Tatiane Gonçalves Sá – Universidade do Estado do Pará

Prof<sup>ª</sup> Dr<sup>ª</sup> Mylena Andréa Oliveira Torres – Universidade Ceuma

Prof<sup>ª</sup> Dr<sup>ª</sup> Natiéli Piovesan – Instituto Federaci do Rio Grande do Norte

Prof. Dr. Paulo Inada – Universidade Estadual de Maringá

Prof. Dr. Rafael Henrique Silva – Hospital Universitário da Universidade Federal da Grande Dourados

Prof<sup>ª</sup> Dr<sup>ª</sup> Regiane Luz Carvalho – Centro Universitário das Faculdades Associadas de Ensino

Prof<sup>ª</sup> Dr<sup>ª</sup> Renata Mendes de Freitas – Universidade Federal de Juiz de Fora

Prof<sup>ª</sup> Dr<sup>ª</sup> Vanessa Lima Gonçalves – Universidade Estadual de Ponta Grossa

Prof<sup>ª</sup> Dr<sup>ª</sup> Vanessa Bordin Viera – Universidade Federal de Campina Grande

### **Ciências Exatas e da Terra e Engenharias**

Prof. Dr. Adélio Alcino Sampaio Castro Machado – Universidade do Porto

Prof. Dr. Carlos Eduardo Sanches de Andrade – Universidade Federal de Goiás

Prof<sup>ª</sup> Dr<sup>ª</sup> Carmen Lúcia Voigt – Universidade Norte do Paraná

Prof. Dr. Cleiseano Emanuel da Silva Paniagua – Instituto Federal de Educação, Ciência e Tecnologia de Goiás

Prof. Dr. Douglas Gonçalves da Silva – Universidade Estadual do Sudoeste da Bahia

Prof. Dr. Eloi Rufato Junior – Universidade Tecnológica Federal do Paraná  
Prof<sup>ª</sup> Dr<sup>ª</sup> Érica de Melo Azevedo – Instituto Federal do Rio de Janeiro  
Prof. Dr. Fabrício Menezes Ramos – Instituto Federal do Pará  
Prof<sup>ª</sup> Dra. Jéssica Verger Nardeli – Universidade Estadual Paulista Júlio de Mesquita Filho  
Prof. Dr. Juliano Carlo Rufino de Freitas – Universidade Federal de Campina Grande  
Prof<sup>ª</sup> Dr<sup>ª</sup> Luciana do Nascimento Mendes – Instituto Federal de Educação, Ciência e Tecnologia do Rio Grande do Norte  
Prof. Dr. Marcelo Marques – Universidade Estadual de Maringá  
Prof. Dr. Marco Aurélio Kistemann Junior – Universidade Federal de Juiz de Fora  
Prof<sup>ª</sup> Dr<sup>ª</sup> Neiva Maria de Almeida – Universidade Federal da Paraíba  
Prof<sup>ª</sup> Dr<sup>ª</sup> Natiéli Piovesan – Instituto Federal do Rio Grande do Norte  
Prof<sup>ª</sup> Dr<sup>ª</sup> Priscila Tessmer Scaglioni – Universidade Federal de Pelotas  
Prof. Dr. Takeshy Tachizawa – Faculdade de Campo Limpo Paulista

### **Linguística, Letras e Artes**

Prof<sup>ª</sup> Dr<sup>ª</sup> Adriana Demite Stephani – Universidade Federal do Tocantins  
Prof<sup>ª</sup> Dr<sup>ª</sup> Angeli Rose do Nascimento – Universidade Federal do Estado do Rio de Janeiro  
Prof<sup>ª</sup> Dr<sup>ª</sup> Carolina Fernandes da Silva Mandaji – Universidade Tecnológica Federal do Paraná  
Prof<sup>ª</sup> Dr<sup>ª</sup> Denise Rocha – Universidade Federal do Ceará  
Prof. Dr. Fabiano Tadeu Grazioli – Universidade Regional Integrada do Alto Uruguai e das Missões  
Prof. Dr. Gilmei Fleck – Universidade Estadual do Oeste do Paraná  
Prof<sup>ª</sup> Dr<sup>ª</sup> Keyla Christina Almeida Portela – Instituto Federal de Educação, Ciência e Tecnologia do Paraná  
Prof<sup>ª</sup> Dr<sup>ª</sup> Miranilde Oliveira Neves – Instituto de Educação, Ciência e Tecnologia do Pará  
Prof<sup>ª</sup> Dr<sup>ª</sup> Sandra Regina Gardacho Pietrobon – Universidade Estadual do Centro-Oeste  
Prof<sup>ª</sup> Dr<sup>ª</sup> Sheila Marta Carregosa Rocha – Universidade do Estado da Bahia

### **Conselho Técnico Científico**

Prof. Me. Abrãao Carvalho Nogueira – Universidade Federal do Espírito Santo  
Prof. Me. Adalberto Zorzo – Centro Estadual de Educação Tecnológica Paula Souza  
Prof. Dr. Adaylson Wagner Sousa de Vasconcelos – Ordem dos Advogados do Brasil/Seccional Paraíba  
Prof. Dr. Adilson Tadeu Basquerote Silva – Universidade para o Desenvolvimento do Alto Vale do Itajaí  
Prof. Dr. Alex Luis dos Santos – Universidade Federal de Minas Gerais  
Prof. Me. Aleksandro Teixeira Ribeiro – Centro Universitário Internacional  
Prof<sup>ª</sup> Ma. Aline Ferreira Antunes – Universidade Federal de Goiás  
Prof. Me. André Flávio Gonçalves Silva – Universidade Federal do Maranhão  
Prof<sup>ª</sup> Ma. Andréa Cristina Marques de Araújo – Universidade Fernando Pessoa  
Prof<sup>ª</sup> Dr<sup>ª</sup> Andreza Lopes – Instituto de Pesquisa e Desenvolvimento Acadêmico  
Prof<sup>ª</sup> Dr<sup>ª</sup> Andrezza Miguel da Silva – Faculdade da Amazônia  
Prof<sup>ª</sup> Ma. Anelisa Mota Gregoleti – Universidade Estadual de Maringá  
Prof<sup>ª</sup> Ma. Anne Karynne da Silva Barbosa – Universidade Federal do Maranhão  
Prof. Dr. Antonio Hot Pereira de Faria – Polícia Militar de Minas Gerais  
Prof. Me. Armando Dias Duarte – Universidade Federal de Pernambuco  
Prof<sup>ª</sup> Ma. Bianca Camargo Martins – UniCesumar

Profª Ma. Carolina Shimomura Nanya – Universidade Federal de São Carlos  
Prof. Me. Carlos Antônio dos Santos – Universidade Federal Rural do Rio de Janeiro  
Prof. Me. Christopher Smith Bignardi Neves – Universidade Federal do Paraná  
Prof. Ma. Cláudia de Araújo Marques – Faculdade de Música do Espírito Santo  
Profª Drª Cláudia Taís Siqueira Cagliari – Centro Universitário Dinâmica das Cataratas  
Prof. Me. Clécio Danilo Dias da Silva – Universidade Federal do Rio Grande do Norte  
Prof. Me. Daniel da Silva Miranda – Universidade Federal do Pará  
Profª Ma. Daniela da Silva Rodrigues – Universidade de Brasília  
Profª Ma. Daniela Remião de Macedo – Universidade de Lisboa  
Profª Ma. Dayane de Melo Barros – Universidade Federal de Pernambuco  
Prof. Me. Douglas Santos Mezacas – Universidade Estadual de Goiás  
Prof. Me. Edevaldo de Castro Monteiro – Embrapa Agrobiologia  
Prof. Me. Eduardo Gomes de Oliveira – Faculdades Unificadas Doctum de Cataguases  
Prof. Me. Eduardo Henrique Ferreira – Faculdade Pitágoras de Londrina  
Prof. Dr. Edwaldo Costa – Marinha do Brasil  
Prof. Me. Eliel Constantino da Silva – Universidade Estadual Paulista Júlio de Mesquita  
Prof. Me. Ernane Rosa Martins – Instituto Federal de Educação, Ciência e Tecnologia de Goiás  
Prof. Me. Euvaldo de Sousa Costa Junior – Prefeitura Municipal de São João do Piauí  
Prof. Dr. Everaldo dos Santos Mendes – Instituto Edith Theresa Hedwing Stein  
Prof. Me. Ezequiel Martins Ferreira – Universidade Federal de Goiás  
Profª Ma. Fabiana Coelho Couto Rocha Corrêa – Centro Universitário Estácio Juiz de Fora  
Prof. Me. Fabiano Eloy Atilio Batista – Universidade Federal de Viçosa  
Prof. Me. Felipe da Costa Negrão – Universidade Federal do Amazonas  
Prof. Me. Francisco Odécio Sales – Instituto Federal do Ceará  
Profª Drª Germana Ponce de Leon Ramírez – Centro Universitário Adventista de São Paulo  
Prof. Me. Gevair Campos – Instituto Mineiro de Agropecuária  
Prof. Me. Givanildo de Oliveira Santos – Secretaria da Educação de Goiás  
Prof. Dr. Guilherme Renato Gomes – Universidade Norte do Paraná  
Prof. Me. Gustavo Krahl – Universidade do Oeste de Santa Catarina  
Prof. Me. Helton Rangel Coutinho Junior – Tribunal de Justiça do Estado do Rio de Janeiro  
Profª Ma. Isabelle Cerqueira Sousa – Universidade de Fortaleza  
Profª Ma. Jaqueline Oliveira Rezende – Universidade Federal de Uberlândia  
Prof. Me. Javier Antonio Albornoz – University of Miami and Miami Dade College  
Prof. Me. Jhonatan da Silva Lima – Universidade Federal do Pará  
Prof. Dr. José Carlos da Silva Mendes – Instituto de Psicologia Cognitiva, Desenvolvimento Humano e Social  
Prof. Me. Jose Elyton Batista dos Santos – Universidade Federal de Sergipe  
Prof. Me. José Luiz Leonardo de Araujo Pimenta – Instituto Nacional de Investigación Agropecuaria Uruguay  
Prof. Me. José Messias Ribeiro Júnior – Instituto Federal de Educação Tecnológica de Pernambuco  
Profª Drª Juliana Santana de Curcio – Universidade Federal de Goiás  
Profª Ma. Juliana Thaisa Rodrigues Pacheco – Universidade Estadual de Ponta Grossa  
Profª Drª Kamilly Souza do Vale – Núcleo de Pesquisas Fenomenológicas/UFPA  
Prof. Dr. Kárpio Márcio de Siqueira – Universidade do Estado da Bahia  
Profª Drª Karina de Araújo Dias – Prefeitura Municipal de Florianópolis  
Prof. Dr. Lázaro Castro Silva Nascimento – Laboratório de Fenomenologia & Subjetividade/UFPR

Prof. Me. Leonardo Tullio – Universidade Estadual de Ponta Grossa  
Prof<sup>ª</sup> Ma. Lillian Coelho de Freitas – Instituto Federal do Pará  
Prof<sup>ª</sup> Ma. Liliani Aparecida Sereno Fontes de Medeiros – Consórcio CEDERJ  
Prof<sup>ª</sup> Dr<sup>ª</sup> Livia do Carmo Silva – Universidade Federal de Goiás  
Prof. Dr. Lucio Marques Vieira Souza – Secretaria de Estado da Educação, do Esporte e da Cultura de Sergipe  
Prof. Dr. Luan Vinicius Bernardelli – Universidade Estadual do Paraná  
Prof<sup>ª</sup> Ma. Luana Ferreira dos Santos – Universidade Estadual de Santa Cruz  
Prof<sup>ª</sup> Ma. Luana Vieira Toledo – Universidade Federal de Viçosa  
Prof. Me. Luis Henrique Almeida Castro – Universidade Federal da Grande Dourados  
Prof<sup>ª</sup> Ma. Luma Sarai de Oliveira – Universidade Estadual de Campinas  
Prof. Dr. Michel da Costa – Universidade Metropolitana de Santos  
Prof. Me. Marcelo da Fonseca Ferreira da Silva – Governo do Estado do Espírito Santo  
Prof. Dr. Marcelo Máximo Purificação – Fundação Integrada Municipal de Ensino Superior  
Prof. Me. Marcos Aurelio Alves e Silva – Instituto Federal de Educação, Ciência e Tecnologia de São Paulo  
Prof<sup>ª</sup> Ma. Maria Elanny Damasceno Silva – Universidade Federal do Ceará  
Prof<sup>ª</sup> Ma. Marileila Marques Toledo – Universidade Federal dos Vales do Jequitinhonha e Mucuri  
Prof. Me. Pedro Panhoca da Silva – Universidade Presbiteriana Mackenzie  
Prof<sup>ª</sup> Dr<sup>ª</sup> Poliana Arruda Fajardo – Universidade Federal de São Carlos  
Prof. Me. Ricardo Sérgio da Silva – Universidade Federal de Pernambuco  
Prof. Me. Renato Faria da Gama – Instituto Gama – Medicina Personalizada e Integrativa  
Prof<sup>ª</sup> Ma. Renata Luciane Polsaque Young Blood – UniSecal  
Prof. Me. Robson Lucas Soares da Silva – Universidade Federal da Paraíba  
Prof. Me. Sebastião André Barbosa Junior – Universidade Federal Rural de Pernambuco  
Prof<sup>ª</sup> Ma. Silene Ribeiro Miranda Barbosa – Consultoria Brasileira de Ensino, Pesquisa e Extensão  
Prof<sup>ª</sup> Ma. Solange Aparecida de Souza Monteiro – Instituto Federal de São Paulo  
Prof<sup>ª</sup> Ma. Taiane Aparecida Ribeiro Nepomoceno – Universidade Estadual do Oeste do Paraná  
Prof. Me. Tallys Newton Fernandes de Matos – Faculdade Regional Jaguaribana  
Prof<sup>ª</sup> Ma. Thatianny Jasmine Castro Martins de Carvalho – Universidade Federal do Piauí  
Prof. Me. Tiago Silvio Dedoné – Colégio ECEL Positivo  
Prof. Dr. Welleson Feitosa Gazel – Universidade Paulista



## Engenharia elétrica: desenvolvimento e inovação tecnológica

**Editora Chefe:** Profª Drª Antonella Carvalho de Oliveira  
**Bibliotecária:** Janaina Ramos  
**Diagramação:** Maria Alice Pinheiro  
**Correção:** Mariane Aparecida Freitas  
**Edição de Arte:** Luiza Alves Batista  
**Revisão:** Os Autores  
**Organizadores:** João Dallamuta  
Henrique Ajuz Holzmann

### Dados Internacionais de Catalogação na Publicação (CIP)

E57 Engenharia elétrica: desenvolvimento e inovação tecnológica / Organizadores João Dallamuta, Henrique Ajuz Holzmann. – Ponta Grossa - PR: Atena, 2021.

Formato: PDF  
Requisitos de sistema: Adobe Acrobat Reader  
Modo de acesso: World Wide Web  
Inclui bibliografia  
ISBN 978-65-5706-773-4  
DOI 10.22533/at.ed.734212202

1. Engenharia elétrica. I. Dallamuta, João (Organizador). II. Holzmann, Henrique Ajuz (Organizador). III. Título.

CDD 621.3

Elaborado por Bibliotecária Janaina Ramos – CRB-8/9166

**Atena Editora**  
Ponta Grossa – Paraná – Brasil  
Telefone: +55 (42) 3323-5493  
[www.atenaeditora.com.br](http://www.atenaeditora.com.br)  
contato@atenaeditora.com.br

## DECLARAÇÃO DOS AUTORES

Os autores desta obra: 1. Atestam não possuir qualquer interesse comercial que constitua um conflito de interesses em relação ao artigo científico publicado; 2. Declaram que participaram ativamente da construção dos respectivos manuscritos, preferencialmente na: a) Concepção do estudo, e/ou aquisição de dados, e/ou análise e interpretação de dados; b) Elaboração do artigo ou revisão com vistas a tornar o material intelectualmente relevante; c) Aprovação final do manuscrito para submissão.; 3. Certificam que os artigos científicos publicados estão completamente isentos de dados e/ou resultados fraudulentos; 4. Confirmam a citação e a referência correta de todos os dados e de interpretações de dados de outras pesquisas; 5. Reconhecem terem informado todas as fontes de financiamento recebidas para a consecução da pesquisa.

## **APRESENTAÇÃO**

Não há padrões de desempenho em engenharia elétrica e da computação que sejam duradouros. Desde que Gordon E. Moore fez a sua clássica profecia tecnológica, em meados dos anos 60, a qual o número de transistores em um chip dobraria a cada 18 meses - padrão este válido até hoje – muita coisa mudou. Permanece porém a certeza de que não há tecnologia na neste campo do conhecimento que não possa ser substituída a qualquer momento por uma nova, oriunda de pesquisa científica nesta área.

Produzir conhecimento em engenharia elétrica é, portanto, atuar em fronteiras de padrões e técnicas de engenharia. Também se trata de uma área de conhecimento com uma grande amplitude de sub áreas e especializações, algo desafiador para pesquisadores e engenheiros.

Neste livro temos uma diversidade de temas nas áreas níveis de profundidade e abordagens de pesquisa, envolvendo aspectos técnicos e científicos. Aos autores e editores, agradecemos pela confiança e espírito de parceria.

Boa leitura

João Dallamuta  
Henrique Ajuz Holzmann

## SUMÁRIO

### **CAPÍTULO 1..... 1**

#### **METODOLOGIA PARA TESTE E CLASSIFICAÇÃO DE SMART METERS PARA APLICAÇÕES EM REDES ELÉTRICAS INTELIGENTES**

Luiz Henrique Leite Rosa  
Renan Corrêa de Moura  
Marcio Ribeiro Cruz  
Carlos Frederico Meschini Almeida  
Nelson Kagan  
Alexandre Dominice

**DOI 10.22533/at.ed.7342122021**

### **CAPÍTULO 2..... 13**

#### **ESTUDO COMPARATIVO DE VIABILIDADE TÉCNICA DA UTILIZAÇÃO DE MOTORES DE INDUÇÃO TRIFÁSICOS EM VEÍCULOS ELÉTRICOS LEVES**

Pedro Henrique Camargos  
Ricardo Elias Caetano  
Marcel Fernando da Costa Parentoni

**DOI 10.22533/at.ed.7342122022**

### **CAPÍTULO 3..... 25**

#### **COMO ATENUAR EMI EM SISTEMAS AUTOMATIZADOS**

Rogério Martins de Souza

**DOI 10.22533/at.ed.7342122023**

### **CAPÍTULO 4..... 39**

#### **MODELO MATEMÁTICO DE UMA TURBINA A GÁS DE 106 MW DE TIPO INDUSTRIAL COM UM ÚNICO EIXO**

Manuel Arturo Rendón Maldonado  
André Reinaldo Novgorodcev Júnior

**DOI 10.22533/at.ed.7342122024**

### **CAPÍTULO 5..... 54**

#### **PROTEÇÃO DIFERENCIAL DE LINHAS - UMA ABORDAGEM USANDO SAMPLED VALUES**

Matheus Felipe Ayello Leite  
Arthur Augusto Pereira Cruz  
Angelo Cesar Colombini  
Márcio Zamboti Fortes  
Yona Lopes

**DOI 10.22533/at.ed.7342122025**

### **CAPÍTULO 6..... 71**

#### **O USO DE DISPOSITIVOS DE PROTEÇÃO CONTRA SURTOS DIANTE DAS RECLAMAÇÕES POR DANOS ELÉTRICOS NO BRASIL**

Lívy Wana Duarte de Souza Nascimento  
Lilian de Fátima Costa Santos

Roberto Akira Yamachita  
Jamil Haddad  
Rodolfo Esmarady Rocha dos Santos  
Neiva Beatriz Ferreira Silva Vicentin  
Carlos Alberto Froés Lima

**DOI 10.22533/at.ed.7342122026**

**CAPÍTULO 7..... 83**

**AVALIAÇÃO DO CONSUMO DE ENERGIA DO HOSPITAL DE CLÍNICAS DA UNIVERSIDADE FEDERAL DO TRIÂNGULO MINEIRO**

Álvaro Ribeiro Gomes de Oliveira  
Arnaldo José Pereira Rosentino Júnior  
Nivaldo Leite da Silva Júnior

**DOI 10.22533/at.ed.7342122027**

**CAPÍTULO 8..... 97**

**ENSAIOS PARA DETERMINAÇÃO DO RENDIMENTO EM MOTORES DE INDUÇÃO TRIFÁSICOS: OPERAÇÃO E MONITORAMENTO COM AUXÍLIO DE FONTE PROGRAMÁVEL**

Cássio Alves de Oliveira  
Josemar Alves dos Santos Junior  
Marcos José de Moraes Filho  
Vinícius Marcos Pinheiro  
Augusto Wohlgemuth Fleury Veloso da Silveira  
Luciano Coutinho Gomes

**DOI 10.22533/at.ed.7342122028**

**CAPÍTULO 9..... 112**

**ANÁLISE DA INFLUÊNCIA DA TEMPERATURA PARA PREVISÃO DE POTÊNCIA MÁXIMA EM SUBESTAÇÕES UTILIZANDO REDES NEURAIS**

Thommas Kevin Sales Flores  
Pedro Henrique Meira de Andrade  
Isaac Emmanuel Azevedo de Medeiros  
Juan Moises Mauricio Villanueva

**DOI 10.22533/at.ed.7342122029**

**CAPÍTULO 10..... 126**

**DETECÇÃO E CLASSIFICAÇÃO DE CURTO-CIRCUITOS UTILIZANDO A TRANSFORMADA DISCRETA FRACIONÁRIA DE FOURIER E REDE NEURAL ARTIFICIAL**

Leonardo Audalio Ferreira do Nascimento  
Viviane Barrozo da Silva Duarte Ricciotti  
Antônio Carlos Duarte Ricciotti  
Adailton Braga Júnior  
Paulo de Tarso Carvalho de Oliveira  
Júlio César Ribeiro

**DOI 10.22533/at.ed.73421220210**



<b>CAPÍTULO 11</b> .....	<b>138</b>
<b>DESENVOLVIMENTO DE UM SISTEMA DE MEDIÇÃO DA COBERTURA DE APLICAÇÃO DE DEFENSIVO AGRÍCOLA USANDO MARCADORES ULTRAVIOLETA</b>	
Edson d'Avila Antônio Carlos Loureiro Lino Inácio Maria Dal Fabbro Ana Cristina da Silva	
<b>DOI 10.22533/at.ed.73421220211</b>	
<b>CAPÍTULO 12</b> .....	<b>149</b>
<b>MODELAGEM E CONTROLE DE UM HELICÓPTERO DE BANCADA COM TRÊS GRAUS DE LIBERDADE</b>	
Matheus Sachet Rômulo Lira Milhomem	
<b>DOI 10.22533/at.ed.73421220212</b>	
<b>CAPÍTULO 13</b> .....	<b>169</b>
<b>ESTUDO DE VIABILIDADE DE IMPLANTAÇÃO DE ESTUFAS HIDROPÔNICAS INTEGRADAS À IOT PARA FINS RESIDENCIAIS</b>	
Rogério Luis Spagnolo da Silva Renan Pinho Lucas Ramalho Paiva Jorge Augusto Igor Falla Henrique Alvarez	
<b>DOI 10.22533/at.ed.73421220213</b>	
<b>CAPÍTULO 14</b> .....	<b>183</b>
<b>SEGMENTAÇÃO DE EXUDATOS DUROS USANDO LIMIAÇÃO ADAPTATIVA E CRESCIMENTO DE REGIÕES</b>	
Rafael de Freitas Brito Milena Bueno Pereira Carneiro Cristiane de Fátima dos Santos Cardoso	
<b>DOI 10.22533/at.ed.73421220214</b>	
<b>CAPÍTULO 15</b> .....	<b>192</b>
<b>MICROGRID SYSTEM DESIGN BASED ON MODEL BASED SYSTEMS ENGINEERING: THE CASE STUDY IN THE AMAZON REGION</b>	
Miguel Angel Orellana Postigo José Reinaldo Silva	
<b>DOI 10.22533/at.ed.73421220215</b>	
<b>CAPÍTULO 16</b> .....	<b>208</b>
<b>ESTUDO COMPLEMENTAR DO USO DE UMA FONTE RESSONANTE PARA TESTES EXPERIMENTAIS DE FALTAS DE ALTA IMPEDÂNCIA EM NÍVEIS DE MÉDIA TENSÃO</b>	
André Pinto Leão Maria Emília Lima Tostes João Paulo Abreu Vieira	

Ubiratan Holanda Bezerra  
Marcelo Costa Santos  
Ádrea Lima de Sousa  
Wesley Rodrigues Heringer  
Murillo Augusto Melo Cordeiro  
Juan Carlos Huaquisaca Paye  
Lucas de Paula Assunção Pinheiro

**DOI 10.22533/at.ed.73421220216**

**CAPÍTULO 17.....224**

**FERRAMENTAS DE PROTOTIPAÇÃO APLICADAS A SISTEMAS DE POTÊNCIA:  
MATLAB VERSUS PYTHON**

Luciano de Oliveira Daniel  
Sergio Luis Varricchio

**DOI 10.22533/at.ed.73421220217**

**CAPÍTULO 18.....240**

**SENSIBILIDADES DE POLOS E ZEROS EM RELAÇÃO AO COMPRIMENTO DE LINHAS  
DE TRANSMISSÃO REPRESENTADAS PELO MODELO DE BERGERON**

Sergio Luis Varricchio  
Cristiano de Oliveira Costa

**DOI 10.22533/at.ed.73421220218**

**CAPÍTULO 19.....256**

**UTILIZAÇÃO DE SIMULADORES EM CENÁRIOS DE REDES ÓPTICAS COM  
MULTIPLEXAÇÃO POR DIVISÃO ESPACIAL**

Eloisa Bento Sarmento  
Mariana Gomes Costa  
Gileno Bezerra Guerra Junior  
Helder Alves Pereira

**DOI 10.22533/at.ed.73421220219**

**CAPÍTULO 20.....264**

**PROJETO E ANÁLISE DE UM ARRANJO LINEAR DE ANTENAS DE MICROFITA QUASE-  
FRACTAL UTILIZANDO A CURVA DE MINKOWSKI NÍVEL 2 COM APLICAÇÕES EM  
REDES DE COMUNICAÇÃO SEM FIO**

Elder Eldervitch Carneiro de Oliveira  
Pedro Carlos de Assis Júnior  
Relber Antônio Galdino de Oliveira

**DOI 10.22533/at.ed.73421220220**

**CAPÍTULO 21.....277**

**UMA NOVA ABORDAGEM PARA O PROBLEMA DAS IMPRECIÇÕES NUMÉRICAS  
RESULTANTES DA UTILIZAÇÃO DE FILTROS COM ARITMÉTICA INTEIRA**

Daniel Carrijo Polonio Araujo  
Gabriel de Souza Pereira Gomes  
Christos Aristóteles Harissis  
Rogério Andrade Flauzino

**DOI 10.22533/at.ed.73421220221**

<b>CAPÍTULO 22</b> .....	<b>298</b>
<b>TÉCNICAS DE DETECÇÃO DE CORRENTE NULA PARA APLICAÇÕES EM CONVERSORES BOOST OPERANDO EM MODO DE CONDUÇÃO CRÍTICA</b>	
Marcelo Nogueira Tirolli	
Alexandre Borges Marcelo	
Flávio Alessandro Serrão Gonçalves	
<b>DOI 10.22533/at.ed.73421220222</b>	
<b>CAPÍTULO 23</b> .....	<b>312</b>
<b>A STAIRWAY STATISTICAL NEURAL MODEL FOR DGA ANALYSIS</b>	
Gabriel de Souza Pereira Gomes	
Daniel Carrijo Polonio Araujo	
Mateus Batista de Moraes	
Rafael Prux Fehlberg	
Murilo Marques Pinto	
Arthur Franklim Marques de Campos	
Marcos Eduardo Guerra Alves	
Rogério Andrade Flauzino	
<b>DOI 10.22533/at.ed.73421220223</b>	
<b>CAPÍTULO 24</b> .....	<b>325</b>
<b>LATÊNCIA NA COMUNICAÇÃO PARA ESQUEMAS DE TELEPROTEÇÃO: REQUISITOS, AVALIAÇÕES E MEIOS DE TRANSMISSÃO</b>	
Mayara Helena Moreira Nogueira dos Santos	
Matheus Felipe Ayello	
Paulo Henrique Barbosa de Souza Pinheiro	
André da Costa Pinho	
Angelo Cesar Colombini	
Márcio Zamboti Fortes	
Yona Lopes	
<b>DOI 10.22533/at.ed.73421220224</b>	
<b>SOBRE OS ORGANIZADORES</b> .....	<b>343</b>
<b>ÍNDICE REMISSIVO</b> .....	<b>344</b>

## MICROGRID SYSTEM DESIGN BASED ON MODEL BASED SYSTEMS ENGINEERING: THE CASE STUDY IN THE AMAZON REGION

*Data de aceite: 04/02/2021*

### **Miguel Angel Orellana Postigo**

Departamento de Engenharia Elétrica /  
Eletrônica, Universidade do Estado do  
Amazonas  
Manaus/AM, Brasil

### **José Reinaldo Silva**

Design Lab, Departamento de Engenharia  
Mecatrônica, Escola Politécnica, Universidade  
de São Paulo  
São Paulo/SP, Brasil

**ABSTRACT:** Microgrid is a technically and economically viable opportunity to meet the demands of populations that, for various reasons, do not have access to electricity. The complexity of Smart Grid (SG) systems requires considerable engineering effort in the design process. Designing this type of complex system requires new approaches, methods, concepts and engineering tools. Where, requirements analysis plays a major role in better characterizing, understanding and specifying the domain of application that SG systems should solve. This work presents a systemic proposal based specifically on System Systems (SoS) which anticipates the formalization of requirements, aiming to understand, analyze and design SG within the scope of Model Based Systems Engineering (MBSE). The definition of a microgrid from the SoS perspective is presented in order to provide a complete view of its life cycle. Requirements

would be represented in an Objective Oriented Requirements Engineering (GORE) approach, specifically using visual diagrams based on the Keep All Objectives Satisfied (KAOS) method, where network operation and control will be formally represented. A case study for small communities in the equatorial Amazon forest is used as a case study for the proposed method.

**KEYWORDS:** Smart Grid; System Design; MBSE; Requirements Engineering; KAOS.

**RESUMO:** As microgrid surgem como uma oportunidade técnica e economicamente viável de atender a demanda das populações que, por diversos motivos, não têm acesso à energia elétrica. A complexidade de sistemas Smart Grid (SG), exigem um esforço considerável de engenharia no processo de design. Para realizar o Design deste tipo de sistemas complexos, são necessárias novas abordagens, métodos, conceitos e ferramentas de engenharia. Onde, a análise de requisitos tem um papel preponderante para melhor caracterizar, entender e especificar o domínio de aplicação e o problema que os sistemas SG devem resolver. Neste trabalho apresenta-se uma proposta sistêmica baseada especificamente em Sistema de Sistemas (SoS) que antecipa a formalização dos requisitos, visando entender, analisar e projetar SG dentro do escopo de Engenharia de Sistemas Baseados em Modelos (MBSE). Apresenta-se a definição de uma microgrid na perspectiva de SoS no intuito de fornecer uma visão completa do seu ciclo de vida. Os requisitos seriam representados em uma abordagem de Engenharia de Requisitos Orientada a Objetivos (GORE), especificamente

usando diagramas visuais com base no método Keep All Objectives Satisfied (KAOS), onde a operação e o controle da rede serão formalmente representados. Um estudo de caso para pequenas comunidades na floresta equatorial da Amazônia é usado como estudo de caso para o método proposto.

**PALAVRAS-CHAVE:** Smart Grid; Projeto de sistemas; MBSE; Engenharia de Requisitos; KAOS.

## 1 | INTRODUCTION

Electricity is an indispensable item for the existence of any human being. However, according to the Brazilian Institute of Geography and Statistics (IBGE), in 2010 about 729,000 Brazilian families had no access to any energy resources, mainly due to their location (IBGE, 2019).

One of the main reasons for the lack of electricity in the lives of thousands of people in Brazil and around the world is the condition of poverty combined with the situation of geographical isolation in which they find themselves. However, despite the criticality, this panorama has been changed over time.

Advances in research and development of energy alternatives based on renewable sources are changing this scenario. In this context, microgrid arises as a technically and economically viable opportunity to meet the demand of populations who, for various reasons, had never (or have limited form) access to electricity.

Implementing Smart Grid (SG) systems has a viable alternative to diversifying and streamlining energy supply needs, where fossil fuels are being replaced by renewable sources (solar and wind generators, biomass and combined heat and power systems, etc.) (Lisserre, Sauter & Hung 2010). The integration of renewable sources and changes in the consumption side are causing new challenges and offering opportunities in the electricity sector.

In this context, microgrid is emerging as a new research area in Brazil that is essential for the care of isolated communities. However, there are still gaps in the technical, economic and management fields. Addressing these technical and operational issues represents a breakthrough in knowledge, which can be translated into benefits for the microgrid assisted consumer through improvements in the quality of energy supplied and an economical tariff, as well as for the utility, through the implementation more efficient and sustainable systems

Recent advances in design concepts, due to the paradigm shift in design from “product” to “service” systems, lead us to think of the SG system as a modern provider of energy services utilizing renewable natural resources that must provide a reliable power system that can be intelligently deployed to facilitate system generation, distribution, and management in this new context, with active user participation (prosumer).

The Basic System Engineering Model (MBSE) method within the scope of Systems of Systems (SoS) can help to understand the new SG landscape, that is, to understand how



their main components report and can be shared. These interrelationships need not only consider the distribution and supply of energy, but also consider environmental compatibility, economic impacts, among other factors.

The introduction of a structured requirements phase in the life cycle of SG systems is a recent trend, and has attracted the attention of researchers and designers. Some existing methods even consider a requirements phase in the lifecycle of this type of system, but do not fully meet the requirements phase (consisting of elicitation, analysis, validation, formal modeling, verification), only satisfying some preliminary steps informally.

Through SoS, it's possible to identify SG system requirements that include strategic, financial, and customer experience functions. At the same time, SoS allows the specification of requirements needed to integrate these new technologies with legacy systems.

It is important to note that working with informal requirements, while facilitating the design process outside the academy, can lead to undetected failures during specification requirements (where error costs are lower), encumbering the project as a whole. The difficulty in dealing with a distributed arrangement of subsystems is another important factor in justifying the use of formally closed and consistent methods that can be analyzed and verified prior to implementation.

In this paper we present a method proposal for the formal specification of requirements applied to the domain of microgrid systems. The proposal is based on a systemic approach, specifically Systems of Systems (SoS) that anticipates the formalization of requirements through the use of Objective Requirements Engineering (GORE) method and within the scope of MBSE (Lopes, Lezama & Pineda, 2011) The adoption of modeling and formal verification techniques is suggested to ensure efficiency and correctness in the design and development of these types of systems.

## 2 | BACKGROUND

The evolution of energy systems, especially smart grids, is directing designers and researchers to produce increasingly powerful and complex energy systems, integrated systems and tightly coupled with many elements belonging to various fields of knowledge, (Gerber, 2014).

Several researches related to the design of energy systems have been recently performed, searching for new more robust and consistent (and more flexible) methods, with different objectives, thus, some related published works are shown below:

In this context, Gerber (Gerber, 2014) presents a method applied to renewable energy systems proposing a Life Cycle Assessment (LCV) using multi-objective optimization techniques.

Other works, such as the one presented by Roboam (Roboam, 2012), use a systemic approach to power system design through the use of the “V” type interactive design cycle

and the use of formal methods. Frangopoulos (Frangopoulos, Von Spakovsky & Sciubba, 2002) used graph theory to model such systems.

Recently proposed models and architectures, such as the IntelliGrid architecture presented by the Electric Power Research Institute (EPRI, USA) (Commission et al. 2008) and the SGAM (Uslar, Specht, Dănekas, Trefke, Rohjans, González, Rosinger & Bleiker, 2012) architecture, recognizing the importance of the phase requirements, and including an approach to IEC / PAS 62559 requirements elicitation using Unified Modeling Language (UML), which consists of the development of a Transmission, Distribution, and Integration Requirement Use Cases repository for the design of Smart Grid systems.

## **2.1 New Proposed Approach for SG Systems Design**

Characteristics regarding the complexity and sophistication of SG systems are leading Designers and researchers to look for new systems design methods and, alternatives. In this context, comes the Model Based Systems Engineering (MBSE). According to the International Council for Systems Engineering (INCOSE), (INCOSE 2015) defines MBSE as the formal application of modeling to support system requirements, design, analysis, verification and validation of activities, at all stages of the cycle project life. In addition, MBSE has several frameworks for systematically examining different views of the corporate system, such as business view, system, technology, operations, and service.

From the point of view of the System Design it turns out that the “ideal” design, seeks correctness and completeness, which can only be achieved with formalization. However, the more formal the system, the more difficult is the communication between its elements: requirement (what has to be done and why), design (how to achieve the system and its objectives directly and with less cost and greater efficiency), and implementation (how to do, how to eliminate the system, and how to interact effectively with the end user).

But in most cases a new system is required to “replace” an existing one that has become obsolete. So, the process should start by modeling “system-as-is”, that is, the legacy system. The “new requirements” should then demarcate the differences between “system-as-is” and “system-to-be” as shown in Figure 1.

If there is no system-as-is, the recommendation is to build a model with the requirements extracted from the stakeholder. This is going to become system-as-is, whereas system-to-be will be the result of optimization and engineering of the solutions after any negotiation.

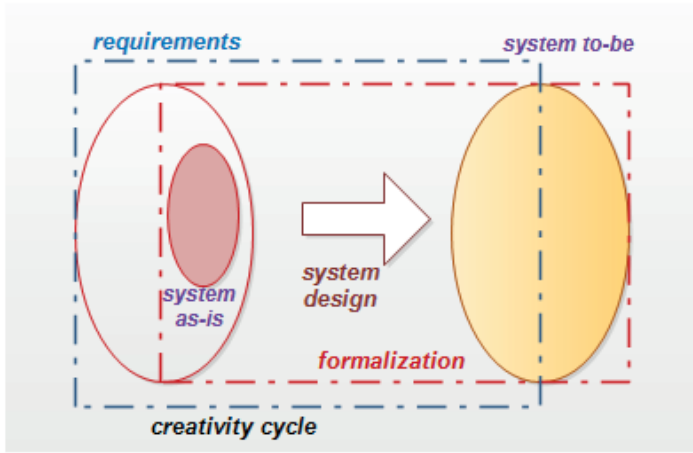

Figure 1: Creativity cycle

Recent advances in design concepts, due to the paradigm shift in design from “product” systems to service systems, lead us to think of models rather than prototypes, aiming to disconnect us from intrinsic functionality of their parts. One way to structure a complex system is to use the concept of hierarchy, that is, to divide it into parts recursively until we understand them and then reassemble the parts to understand the whole.

However, this approach does not help us understand a complex system, because the emerging properties that really matter disappear when we look at the parts in isolation, that is, we cannot treat this new system as just a junction of parts or small subsystems.

In this scenario, the concept of SoS emerges which is defined as a set of constituent systems that seeks harmony among distributed elements (parts), capable of flexibly and adaptably producing distinct behaviors, whether these are the results of the direct contribution of their components or result of joint action, (Lopes et al. 2011).

However, it is verified that the design of a SG system could not be guaranteed by addressing each constituent subsystem separately, it is necessary that these distributed subsystems combine their features and capabilities in order to generate the SG system which offers greater functionality and performance. For this reason, we consider SG as an SoS (Andrén, Strasser & Kastner 2017) and (Uslar, Rohjans et al. 2019).

In order to establish efficient communication between the parts of the SG, it is proposed to apply (MBSE), a method that prioritizes the formalization of requirements from the early stages of the SoS life cycle. This approach that uses graphical representations begins the end thinking, that is, the future vision of the desired system, and serves as a guide for defining and documenting what will be needed in terms of resources, technology, and other.

Therefore, considering the SG system from the MBSE point of view, and verified the

importance of the requirements step, there is a need for a reliable engineering requirement (ER) as an integral component of the proposed method that will lead us to SoS Design. In this context, the proposal is to use the GORE method.

## 2.2 Microgrid System Scenario

Technically, a microgrid is a low voltage distribution network, located downstream of a distribution substation through a Point of Common Connection (PCC). The microgrid consists is a multi-source system composed by conventional Renewable Energy Sources (RES), a storage systems and controllable loads (Lisserre et al. 2010). The interface between the service network and the microgrid is used to interact with the SG; it provides voltage control, power balancing, and load sharing. A communications infrastructure, provide the transfer and exchange of data, in real time, Figure 2.

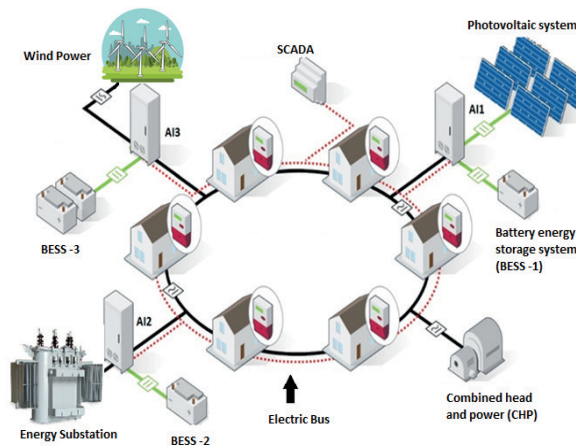

Figure 2: Proposed scenario for the microgrid

Therefore, microgrids play a key role in the integration of distributed generators and, in particularly in the integration of Renewable Energy Sources (RES) (Sechilariu & Locment 2016). However, the intermittent and unpredictable nature of the power supply remains a problem to the integration with the service network, resulting in voltage and / or frequency fluctuations, harmonic pollution, and some difficulty in charge management.

On the other hand, there is great potential to develop and test new technologies for sustainable generation, especially in countries belonging to BRICS. The integration of these technologies has become a priority in microgrids in response to the pressure to implement a net of distributed energy resources, also including the integration of intelligent electronic devices. This arrangement should be surrounded by sensing and measurement systems, network nodes with computing capacities, actuation devices to allow supervision and the

proper integration and coupling with user needs.

### 2.3 GORE: Goal-Oriented Requirements Engineering

New approaches to requirements engineering evolved towards requirements management (elicitation, modeling and analysis) based on objectives - instead of functionality - decreasing the traditional dichotomy between functional and non-functional requirements. A requirement is viewed as a necessary condition to reach a goal in a specific application domain (Horko, Aydemir, Cardoso, Li, Maté, Paja, Salnitri, Piras, Mylopoulos & Giorgini 2017).

Functional requirements are more intuitive, generally associated with services provided to customers, in contrast with non-functional requirements, normally related to quality, performance or resources required for the service, and/or related to external demands such as safety, performance, scalability, operability, etc. Thus, in conventional the approach non-functional requirements are frequently neglected or fail to compose a complete and consistent set. Goal-oriented methods became an interesting alternative (Ghezzi & Tamburrelli 2009).

### 2.4 KAOS modeling and the GORE method

KAOS (Knowledge Acquisition in Automated Specification) is a GORE method for modeling requirements as objectives (Horko, Aydemir, Cardoso, Li, Maté, Paja, Salnitri, Piras, Mylopoulos & Giorgini 2019). It is an efficient schema for adjusting descriptions, analyze problems, clarify responsibilities and manage different views between stakeholders. Improvements in traceability, completeness evaluation, reducing of ambiguity in requirement analysis are perceptible advantages of KAOS.

A comprehensive model of requirements is defined by four diagrams (only): Goal, Objects, Responsibility, and Operations, which can be resumed in an LTL (Linear Temporal Logic) formalism. Figure 3, show the main elements of a KAOS diagram.

A goal diagram is a tree in which the root is represented by the main primary objective. This goal could be further refined into sub-objectives (requirements or expectations) which are the leaves of this top-bottom node.

Agents are responsible for satisfying one or more objectives (requirements or expectations). If the agent is part of the system to be developed then the objective is a requirement, whereas if the objective is linked to an agent belonging to the application domain the objective is an expectation.

In some specific situations, goals, requirements, or expectations need to be modeled as obstacles to a goal or requirement fulfillment - a fault detection, for instance.

Using obstacles is essential for safety-critical systems since that allows domain specialist to identify and address exceptional circumstances at the requirements stage, and converge towards robust requirements that could mitigate or avoid obstacles.







 Goal	Goal to be achievement
 Requirement	Goal assigned to single agent in software-to-be.
 Expectation	Goal assigned to single agent in environment.
 Domain Properties	Descriptive statements on environment (physical laws, organizational policies).
 Operation	Operation to be realized to achieve a goal, requirement or expectation.
 Agent	Agent responsible for the achievement of any goal, expectation or requirement

Figure 3: Goal Elements

### 3 | MICROGRID USE CASE

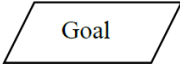
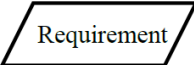
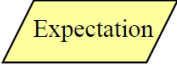
The case study presented here was based on the R&D Project “Microgrids with intermittent sources applied in isolated areas”, presented by the Energy Group of the Department of Automation and Electrical Engineering of Polytechnic School-USP in the year of 2012, (Martinez, Saidel & Fadigas 2012).

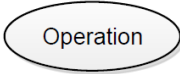
The main objective of this study is, from the legacy system (microgrid), to insert automation, communication, and user participation, and inclusion of other renewable energy resources available in the locale in an efficient and sustainable way, promoting energy quality. In addition, attendance to non-conformities detected in said system.

The process begins by specifying microgrid (legacy system) requirements, applying reverse engineering within the scope of the MBSE and based on the GORE approach. The requirements specification will be refined into two phases, one phase called system As-Is and another called system to-be. In this work we will deal specifically with System As-Is, leaving for future work the elaboration of system To-be.

With the application of Reverse Engineering and through a systemic view is intended to acquire knowledge, it is, collect the functional and non-functional requirements about the legacy system, allowing to identify its functionality the components and their interrelationships. In addition, to delimit the application domain and also to define the scope

of development, that is, to define the subsystems of interest (SoS), the system inputs and outputs, the interfaces and the form of communication with external elements, among others.

Using the GORE and KAOS approach will be created representations (models), whose final result will be the documentation of the requirements. This paper intends to make an analysis of the requirements documentation, when compared with the legacy system design information, in order to show the advantages of the proposed method, as well as the importance of the requirements phase in the life cycle of the SG systems.

### 3.1 System Description

The hybrid microgrid here is the type (photovoltaic-diesel-battery) with a mixed architecture coupled with AC and DC, Figure 4, presents the schematic diagram. This system results from the combination of solar and battery intermittent sources, with diesel generating units, in a single electricity generation system, which takes advantage of the solar resource operating in a combined manner (but not necessarily in parallel) with a diesel generator, with the purpose of meeting a certain load.

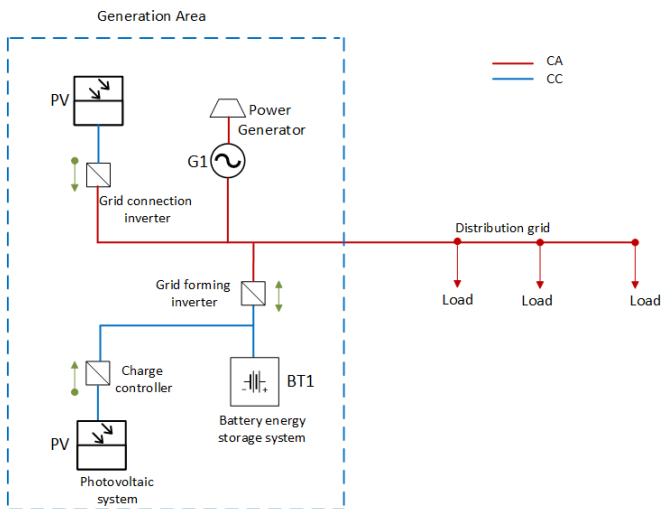

Fig. 4. Microgrid system legacy

In this case, the diesel generator unit may act as the main component when the solar generator is used to save fuel, or it may act as a backup generation unit to ensure microgrid operation during possible periods of unavailability of the solar source.

For monitoring and storing information, the Data Acquisition System (DAS) is used which provides information on system behavior, related to the amount of energy generated and especially that consumed by loads.

Grid inverters are responsible for converting direct current (coming from photovoltaic

panels) to alternating current of constant voltage and frequency. In them it is finds the supervisory control of the system, also has the function of managing the battery bank, avoiding overcharging or deep discharges.

#### 4 | RESULTS AND DISCUSSIONS

The first step of the proposed method is to apply MBSE to “system as-is”, the goal of this phase is to collect the legacy system requirements to understand the scenario, in this case the autonomous microgrid. In order to identify its functionality, its components and its interrelationships. As well as the identification of non-conformities this system.

Using MBSE method GORE and KAOS we will capture the requirements of the MSG system, aiming to model the microgrid system with the same functionalities, to understand the system boundaries from the objectives, expectations and constraints.

Data	Description
Techno-Economic Analysis	Analyzes cost of different technological options;
	Analyzes level of technical capacity available on site to perform system operation and maintenance;
	Analyzes cost of diesel or alternative fuel;
Calculation of Demand to be Met	Evaluates consumer profile to be served;
	Analyzes community layout;
	Performs lifting of loads;
Evaluate availability of energy resources	Evaluate existing infrastructure;
	Evaluates solar radiation index;
Select architecture type	Evaluates transport logistics of diesel oil;
	Selects the type of architecture best suited to local reality, based on IEC 61724;
Choice of equipment	Low power sensors;
	Avoid current loops;
	components that offer system reliability;
Information Handling	Evaluate cost of component replacement.
	Add redundancy in the data acquisition phase to facilitate information processing;
	Use robust transmission signals;
	Maintain a system log;
	Establish the geographic coordinates of the monitoring system.

Table 1. Project Data

The next step of the proposed method is to use Reverse Engineering to extract the information used in project development (legacy system), as shown in Table 1.

It is verified that the information collected is very technical, and important for the system implementation, however, information related to the system quality such as safety, reliability, performance, maintainability, scalability and usability are not present. These attributes are important and serve the constraints on system design.

In addition, the analysis of the legacy system revealed the following non-conformities:

- There was a 240 increase in electricity consumption due to excessive energy consumption and the presence of clandestine connections;
- There was an increase in fuel consumption, caused by increased demand, in addition to the quota provided;

Abnormal operation of the battery banks was observed causing the interruption of the power supply by the grid inverters;

Problems communicating Datalogger for collecting microgrid monitoring data.

In order to collect non-functional requirements, we use the GORE and KAOS methodology as shown in Figure 5.

Following the methodological proposal, the following step is to apply GORE and KAOS in order to model the requirements from a functional and non-functional objective perspective, always directed to the problem and the corresponding solution, from a high-level view.

Therefore, from the legacy system analysis it verifies that the main objective of the legacy system was: “Design, install and monitor Autonomous microgrid”. In this paper we will deal specifically with the part related to the project itself.

In Figure 5, shows the KAOS Objectives Diagram highlighting the main objective “Design Autonomous Microgrid”. This main objective is refined into sub-objectives, to know: Techno-economic analysis, environmental advising and technical constraints, selecting equipment, selecting the type of architecture, advising available energy resources, and calculation of demand be met.

These sub-goals will continue to be refined to the level of requirements or expectations. Thus, for example, to calculate demand, it is necessary to evaluate existing infrastructure, community layout, and especially the consumer profile, which represents the following level of refinement. In the legacy system, no objectives related to performance indicators were observed.

ID	Type	Description
G-1	Design Autonomous Microgrid	Represents the main goal
G-2	Techno-Economic Analysis	It aims to analyze the viability of the investment, comparing the returns that can be obtained with the investments demanded.
G-3	Choice of equipment	Aims to use commercially available technologies / models with cost savings.
G-4	Evaluates technical restrictions	It aims to evaluate the technical limitations related to labor, equipment, available technology.
G-5	Calculation of Demand to be Met	Aims for correct system sizing, system reliability and appropriate community tariffs.
G-6	Evaluate environmental	It aims to assess the environmental impacts of the project as well as relevant permits.
G-7	Evaluate availability of energy resources	It aims to study the system configurations that allow optimizing the use of energy resources in order to ensure security in the supply of electricity and promoting tariff savings.
G-8	Include performance indicators	It aims to identify the causes for which goals are not being met and to analyze opportunities for improvement.
G-9	Evaluates consumer profile to be served	It aims to analyze social, economic and political aspects, conditions of access to communities.
G-10	Evaluate Legal Aspects	Aims to analyze legal aspects related to energy user / supplier contracts.
E-1	environmental licensing	Performs Environmental Licensing.
E-4	Assesses labor availability to maintain system	The System should not be shut down for maintenance more than once in a 24-hour period annually. - Operator should be training in Electrical Installations, NR-10 and programming in Datalogger and Inverters.
E-7	Perform contract	- Performs written agreement establishing the consumer shutdown if no power bill payment; - Zero tolerance to power theft
E-8	Evaluate system reliability	The system must have an MTBF equivalent to 1 / 10,000 of 1/30 days
E-9	Flexible system that can absorb unforeseen loads	Flexible system that can absorb both unforeseen loads and future demands

E-10	Check system operational availability	The system must be available at least 99.0% on working days, 24 hours a day.
E-11	Evaluate system security	- The system must be capable enough to meet the demand of all users in the communities without affecting their performance. – Users are never allowed to manipulate SmartMeter or external installations.
E-12	Evaluates system scalability in (%) of demand	The system will be able to meet peak demand up to (10%) higher than peak hour contracted demand.

Table 2. Project Goal

Thus, in order to meet certain objectives, we have verified the need to include performance attributes such as: Evaluate system scalability, evaluate system security, Check operating system, Evaluate system reability, Flexible system that can absorb unforeseen loads, which represent expectations and is responsible for the System Designer. On the other hand, the case of the “Evaluate the consumer profile” sub-objective was added the objective related to the evaluation of legal aspects, important to fulfill the expectation of contracting and has responsible agents, the user and the utility company.

In the Table 2, shows the functional requirements and system attributes extracted from the KAOS Goals model, this table is the result of the documentation obtained through the KAOS method. Comparing Table 1 with Table 2, is can identify some missing requirements.

The absence of these requirements meant in non-conformities in the legacy system that could have been addressed from the start of the project. Thus, for example, clandestine connections, which overloaded the grid, increasing the demand, which in turn led to increased fuel consumption and abnormal battery operation, could have been clearly identified by those involved in the project.

Therefore, to address the problem of clandestine connections, Table 2, shows the requirements that would address such non-compliance, which are the Legal Requirements, the evaluated System Security, the evaluated system reability, the Evaluated System Scalability, and Integrity of System. Therefore, as we can see, a poorly collected requirement can have negative impacts on the system.

In this context, we realize that the importance of the correct specification of the requirements, and we understand that there is a great difficulty in capturing and describing the information raised, an obstacle often caused by misinterpretation of user needs.

In this case, it was also evidence that demand limited to 100kW/h, with automatic shutdown above that consumption. It is verified turns out that this situation could possibly have been the cause for some users to make clandestine connections, causing imbalance in the system.





methods emphasize functional requirements, leaving non-functional requirements to the background, and none of these methods have a formal requirements step.

Due to the complexity of SG systems, and the importance of the phase requirements in their lifecycle, we understand that it is necessary to provide methods tools and concepts to better characterize, understand and specify the domain of application of these systems. The idea proposed in this paper was to treat SG as a SoS, with the objective of understanding the SG system through a holistic (top-down) view, aiming to avoid delving into some of the aspects before verifying its relation to other aspects of the same or near levels.

To this end, guidelines were provided for the application of a real microgrid-based case study to serve isolated Amazonian communities, the purpose of which was to collect the requirements of the legacy system to enable understanding of the system, in order to identify its functionality, their components and their interrelations, as well as characterize non-conformities in the legacy system.

After applying the proposed methodology, it was found that KAOS turned out to be an effective method to extract objectives from the microgrid, resolving the ambiguity when specifying requirements. It also provided support for their validation and traceability.

With the use of the SoS concept it allowed us greater flexibility in the design, as it made it possible to modify characteristics of the As-Is system without changing what had already been defined, and thus to design the To-Be system.

On the other hand, in the same perspective of complex SoS, the distributed characteristic of the microgrid allowed the sharing of resources between the constituent parts in the context of a larger and evolving system.

Finally, the methodological proposal presented here opens up a promising direction of research for Design and SG systems through a SoS perspective and using modeling and formal verification methods that can be used by designers and researchers of SG systems, contributing to the development of a framework, of practical use.

## **ACKNOWLEDGMENT**

The authors acknowledge their respective institutions for the support to their research activities: University of Amazon State (UEA), FAPEAM, and Escola Politécnica, University of São Paulo (USP).

## **REFERENCES**

Berger, L. T. and Iniewski, K. (2012). Smart grid: applications, communications, and security, Wiley.

Commission, I. E. et al. (2008). Intelligrid Methodology for Developing Requirements for Energy Systems, IEC.

Cretu, L. G. and Dumitriu, F. (2014). *Model-Driven Engineering of Information Systems: Principles, Techniques, and Practice*, CRC Press.

Hongwei, D. (2014). Design and application of microgrid operation control system based on IEC 61850.

Horkoff, J., Aydemir, F. B., Cardoso, E., Li, T., Maf e, A., Paja, E., Salnitri, M., Piras, L., Mylopoulos, J. and Giorgini, P. (2017). Goal-oriented requirements engineering: an extended systematic mapping study, *Requirements Engineering* pp. 1–28.

Mazzolini, M., Brusaferrri, A. and Carpanzano, E. (2011). An integrated framework for mode-based design and verification of discrete automation solutions, *Industrial Informatics (INDIN)*, 2011 9th IEEE International Conference on, IEEE, pp. 545–550.

Naumann, A., Bielchev, I., Voropai, N. and Sty-czynski, Z. (2014). Smart Grid automation using IEC 61850 and CIM standards, *Control Engineering Practice* 25: 102–111.

Postigo, M., Silva, J., & Silva, J. (2018). Formal requirements specification for microgrid based on architecture IEC 61.850. In *proc. of the XXII Brazilian congress on automation*. Brazilian society of automation.

Sechilariu, M. and Locment, F. (2016). *Urban DC Microgrid: Intelligent Control and Power Flow Optimization*, Butterworth-Heinemann.

Silva, J. M. and Silva, J. R. (2015). Combining KAOS and Ghenesys in the requirement and analysis of service manufacturing, *IFAC-Papers OnLine* 48(3): 1634–1639.

Uslar, M., Specht, M., D'anezas, C., Trefke, J., Ro-hjans, S., Gonz'alez, J. M., Rosinger, C. and Bleiker, R. (2012). *Standardization in Smart Grids: introduction to IT-related methodologies, architectures and standards*, Springer Science & Business Media.

## ÍNDICE REMISSIVO

### A

AMI 1, 2, 3, 4, 5, 7, 12, 124

Aneel 6, 52, 71, 72, 73, 74, 75, 76, 77, 79, 81, 84, 96, 127, 136, 209, 221

Aterramento 25, 27, 28, 29, 32, 34, 37, 38, 72, 77, 209

Automação 1, 7, 25, 26, 32, 33, 37, 61, 138, 149, 164, 168, 169, 325, 330, 333, 341

### C

Classificação 1, 12, 126, 128, 131, 134, 135, 136, 184, 209

Compatibilidade Eletromagnética 25

Complexo Hospitalar 83, 84

Consumo de Energia 4, 83, 84, 138, 161, 172, 181, 259, 260

Curto-Circuito 65, 100, 126, 128, 131, 132, 133, 134, 135, 234

### D

Danos Elétricos 71, 72, 73, 76, 80, 82

Defensivos agrícolas 138, 139, 140, 146, 147

Densidade de potência 13, 15, 16, 17, 19

Descargas atmosféricas 27, 71, 76, 328

Detecção de fraudes 1, 10, 11

Distribuição de Energia Elétrica 72, 81, 96, 112, 113, 125, 127, 210, 221, 222

DPS 71, 72, 77, 78, 79, 80, 81

### E

Ensaio 97, 98, 99, 103, 104, 108, 109, 111, 219, 324

Estudo comparativo 13, 15, 275

### I

IEC 61850 54, 55, 61, 62, 63, 67, 68, 69, 70, 207, 330, 331, 332, 333, 339, 340, 341, 342

Inteligência Artificial 112, 114

Interferência Eletromagnética 25, 26, 37, 327, 328

### L

Linhas de transmissão 54, 56, 62, 64, 65, 112, 113, 227, 240, 327

### M

Medição 1, 3, 4, 7, 8, 11, 54, 58, 59, 60, 64, 79, 80, 83, 84, 86, 87, 88, 89, 95, 96, 106, 138,

140, 141, 142, 217, 218, 219, 220, 221, 271, 272, 331, 338

Medidores Inteligentes 1, 4, 6, 7, 8, 9, 10, 11, 12

Mensuração da área de cobertura 138, 139, 140

Modelagem de sistemas de potência 39, 228

Motor de indução 13, 14, 19, 97, 98, 100, 101, 102, 104

Motor de indução trifásico 97, 98, 100, 101, 104

## **N**

Normas Técnicas 81, 97, 99, 110, 111

## **P**

Previsão de Demanda 112, 113, 114, 115, 119, 124, 125

Previsão de Séries Temporais 112

Projetos de Engenharia 25

Proteção de linhas de transmissão 54

Proteção Diferencial 54, 55, 56, 57, 59, 60, 62, 63, 64, 65, 67, 68, 69

## **Q**

Qualidade de energia 1, 11, 76, 96, 126, 127, 128, 217

## **R**

Redes Neurais Artificiais 112, 115, 126, 128, 136

Rendimento 15, 16, 19, 20, 95, 97, 98, 101, 102, 105, 106, 107, 108, 109, 110, 111, 301

Ressarcimento 71, 72, 81, 82

## **S**

Sampled Values 54, 55, 61, 70, 331

Smart Grid 1, 2, 3, 4, 6, 11, 12, 192, 193, 195, 207, 341

Subestação 29, 83, 84, 95, 96, 112, 115, 116, 124, 331

## **T**

Tecnologias de aplicação 138, 139, 140

Termoeletricidade 39

Transformador 83, 85, 87, 88, 89, 90, 91, 92, 93, 94, 95, 132, 212, 213, 221, 313, 337

Turbina a gás 39

Turbogerador 39

## **V**

Veículo elétrico leve 13

Viabilidade Técnica 13, 14, 16